

Name: *Answer Key*  
Hour:

## Cumulative Final Exam Review Guide

### Unit One: Nature of Science

- On a separate sheet of paper write definitions for the following terms
  - Biology
  - Control Group
  - Hypothesis
  - Independent Variable
  - Dependent Variable
  - Constants
- How do you write a proper hypothesis? Provide an example.  
*If then statements*  
*"If I eat an apple, then I will be healthy."*
- List the six steps of the scientific method in order
  - observations*
  - questions*
  - hypothesis*
  - predictions*
  - experiment*
  - analysis/conclusion*
- Read and analyze the following experiment

Dr. Bunsen Honeydew and his assistant Beaker have been working on a cure for Fozzie's bad jokes. After trying to teach Fozzie new jokes, they gave up and decided they had to approach the problem from a different point of view, that of the audience. They have created a formula that looks like water, tastes like water, and is odorless like water. Before Fozzie's show, Bunsen and Beaker split the audience in half. The left side of the audience (group A) was given a bottle of water and asked to drink it all before the show started. The right side of the audience (group B) was given a bottle of the formula and was also asked to drink it all before the show started. After the first few jokes, Fozzie was hit by seven tomatoes, heckled by Waldorf and Statler (as usual) and booed; all by the left side of the audience (group A). The right side of the audience (group B) didn't notice the booing or tomatoes because they were too busy laughing at Fozzie's jokes.

#### Identify the following:

Control Group: *Group A*

Experimental Group: *Group B*

Independent Variable: *formula given to group B.*

Dependent Variable: *Amount of laughter*

Constants: *Same amount of water, drank at same time, same jokes*  
*same room*

### Unit Two: Biochemistry

- On a separate sheet of paper, write definitions for the following terms
  - Organic Compound
  - Photosynthesis
  - Cellular Respiration
  - Aerobic Respiration
  - Anaerobic Respiration/fermentation
  - Macromolecule
  - Monomer

2. Identify the four types of organic compounds and answer the questions about each.

a. Carbohydrates

- i. What are the monomers?  
*monosaccharides*
- ii. What is the polymer?  
*polysaccharides*
- iii. What are the elements that make up this molecule?  
*C, H, O - with a ratio. Double the amount of hydrogens compared to carbon & oxygen.*
- iv. What are they used for?  
*Short term energy storage*
- v. Provide at least one example - *Bread, glucose*

b. Protein

- i. What are the monomers?  
*Amino Acid*
- ii. What is the polymer?  
*polypeptide chain*
- iii. What are the elements that make up this molecule?  
*C, H, O, N, S*
- iv. What are they used for?  
*membrane, enzymes, antibodies, non-steroid hormones, structure*
- v. Provide at least one example - *eggs, steak, chicken*

c. Lipids

- i. What are the monomers?  
*Fatty Acid & glycerol*
- ii. What is the polymer?  
*Lipid - glycerides*
- iii. What are the elements that make up this molecule?  
*CH<sub>2</sub>O*
- iv. What are they used for?  
*organ protection, warmth, structure*
- v. Provide at least one example  
*oils, butters*

d. Nucleic Acids

i. What are the monomers?

Nucleotides

ii. What is the polymer?

Nucleic Acids

iii. What are the elements that make up this molecule?

phosphate, sugars, nitrogen bases

iv. What are they used for?

Carrying genetic material

v. Provide at least one example

DNA & RNA

3. Why is water so important to living things? Provide and explain 7 reasons.

a. Polarity - allows water to be a universal solvent

b. Temperature regulation - allows humans & other organisms on earth to maintain a temperature (steady temp)

c. Surface tension - allows some organisms to walk on water

d. Density - less dense as a solid - floats on liquid water so that organisms can live in the water

e. Adhesion - allows water to stick to other surfaces - making it so that plants can pull water up their stems.

f. Cohesion - water sticking to itself is important so that plants are able to drink water. This also allows waves in oceans which mixes nutrients

g. Universal solvent - able to dissolve many substances so that we can take in many nutrients

4. Why is ATP so important to cells?

ATP provides energy to the cells so that they can function

5. What is the difference between aerobic respiration and anaerobic respiration/fermentation? Which makes more molecules of ATP?

aerobic respiration uses oxygen & produces 38 ATP molecules per glucose molecule.

Anaerobic respiration does not use oxygen, and produces very little oxygen

6. Write out the equation for photosynthesis

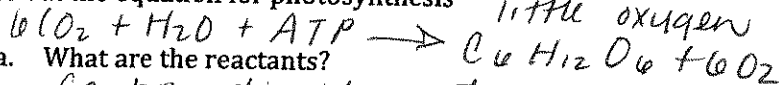

a. What are the reactants?

Carbon dioxide, water, energy

b. What are the products?

Glucose, oxygen

c. What else must be present for photosynthesis to occur?

Sunlight

7. Write out the equation for cellular respiration

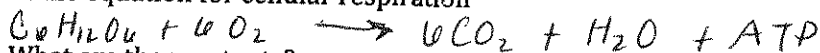

a. What are the reactants?

Glucose, oxygen

b. What are the products?

Carbon dioxide, water, energy

c. What else must be present for cellular respiration to occur? Oxygen

**Unit Three: Cells**

1. On a separate sheet of paper, write definitions for the following terms
 

a. Diffusion	e. Osmosis
b. Passive Transport	f. Active Transport
c. Hypertonic	g. Isotonic
d. Hypotonic	h. Cells
  
2. Explain the function of the organelles listed and then identify the organelles listed on the diagrams on the following page.

Organelle	Function
Mitochondria	Supplies energy to the cell
Nucleus	control center of the cell
Cytoplasm	Material that organelles are found
Nuclear Envelope	surrounds the nucleus
Cell Membrane	protective outer layer of the cell
Golgi Apparatus	Stores & packages materials in the cell-like UPS
Smooth ER	Synthesis of lipids
Rough ER	transports proteins
Ribosomes	Builds proteins.
Vesicles	carries materials through the cell
Central Vacuole	found in plant cells - holds materials & waste
Cell Wall	outside structure of plant cells - keeping the cell in a rigid structure.
Chloroplast	site of photosynthesis in plant cells

found only in plant cells

3. Label the following diagrams

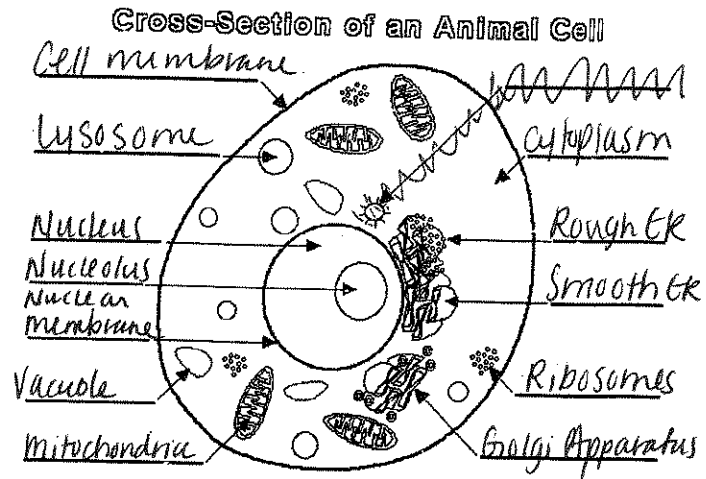
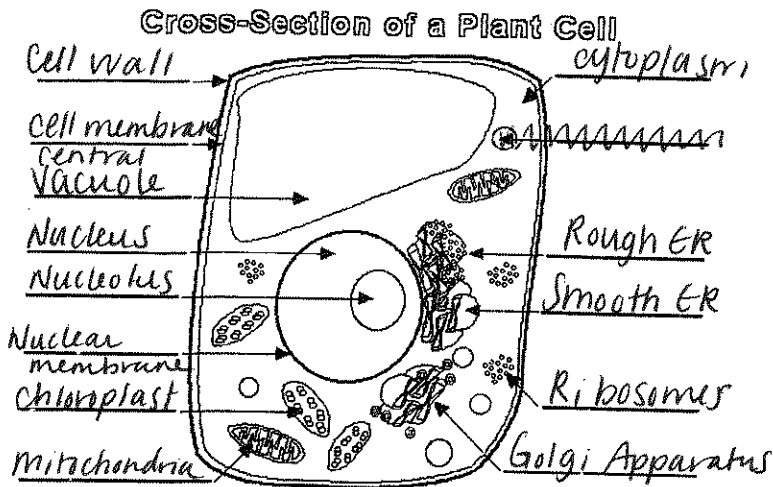

4. Of the two diagrams, which is an animal cell and which is a plant cell? How do you know?

The plant cell is the square looking one because of the cell wall. The circle cell is the animal cell because they lack cell walls.

5. The following table gives you information relating to different types of solutions: hypertonic, isotonic, and hypotonic. Fill in the missing information to identify the solution and what happens to cells in each solution.

If the fluid outside the cell has...	The outside fluid is... (hypertonic, isotonic, hypotonic)	Water diffuses...	Effect on cell (shrivels, stays the same, bursts)
Lower free water molecule concentration than salt	hypertonic	Out of the cell.  H <sub>2</sub> O	shrivels
High free water molecule concentration than salt	hypotonic	Into the cell  H <sub>2</sub> O	bursts
Same free water molecule concentration as salt	isotonic	Into and out of the cell at equal rates  H <sub>2</sub> O	stays the same.

6. Identify the descriptions below as either an example of diffusion (d) or osmosis (o)

- D Two drops of blue food coloring and two drops of yellow food coloring are added to a glass of water, later all of the water is green.
- D The iodine and starch lab that we did in class.
- D A lump of sugar is added to a beaker of water, eventually the sugar is completely dissolved in the water.
- O In an isotonic solution, water molecules move into and out of the cells at the same rate.
- D I spray perfume in the front right corner of the room and it can eventually be smelled in the back left corner of the room.

7. Compare and contrast passive and active transport. Be sure to give examples of each.

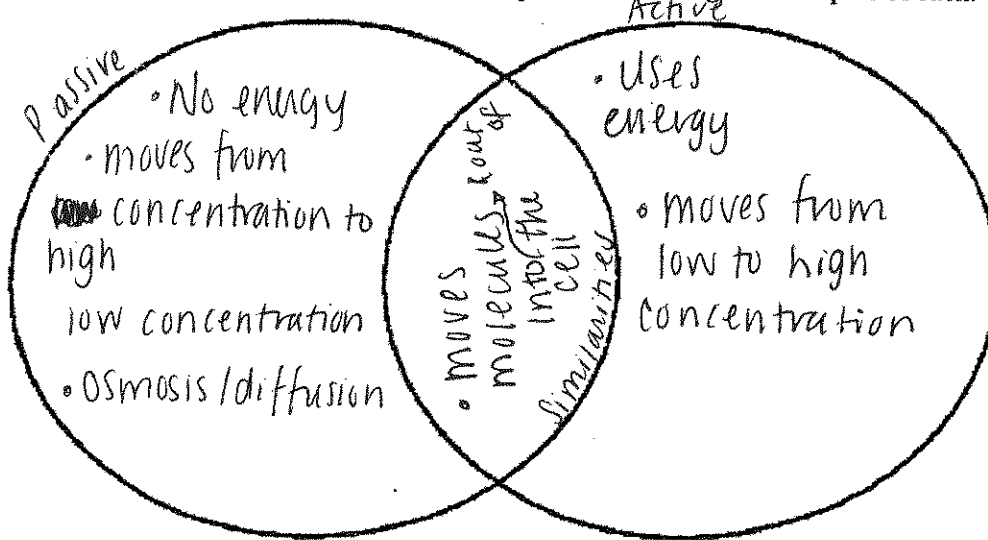

8. Bacteria come in three basic shapes. Give the common and scientific name of each.

- Spirillum - Spiral
- Bacillus - Rod
- Coccus - Sphere

**Unit Four: Cell Division**

1. On a separate sheet of paper, write definitions for the following terms

- |               |                          |
|---------------|--------------------------|
| a. Chromosome | h. Cancer                |
| b. Diploid    | i. Crossing-Over         |
| c. Haploid    | j. Autosome              |
| d. Trisomy    | k. Homologous Chromosome |
| e. Karyotype  | l. Sex-Chromosome        |
| f. Mitosis    | m. Chromatid             |
| g. Meiosis    | n. Centromere            |

2. All of the DNA in a cell is much larger than the cell itself. How does the DNA become more compact to fit inside the nucleus?

It folds back on itself over proteins called histones

3. What combination of sex chromosomes produce males and females in humans?

Males: XY Females: XX

4. If a sperm cell contains 10 chromosomes, how many chromosomes will be in the organism's body cells?

20 chromosomes in a body cell. Body cells are diploid (2n)

5. List three characteristics of cancer cells?

a. Spend less time in interphase

b. Grow faster than normal cells

c. Uncontrolled mitosis - do not stop division after a certain point.

Sperm & egg cells are haploid (n)

6. Use the diagram to answer the following questions

a. What does the diagram represent?

Cell cycle

b. What happens in the G<sub>1</sub>, S, and G<sub>2</sub> stage?

G<sub>1</sub> - Cell Mature, S - DNA copied G<sub>2</sub> -

c. What phase do cells spend the most time in?

Interphase

d. What phase do cells spend the least time in?

Cytokinesis

e. Mitosis is also known as the division of what?

Nuclear Division

f. Which two phases make up cell division?

Cytokinesis & mitosis

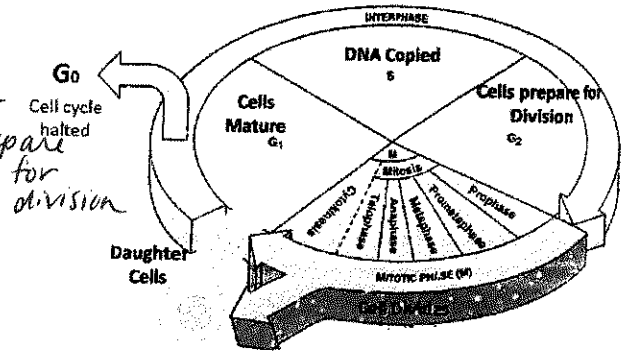

7. Compare and contrast mitosis and meiosis. Be specific.

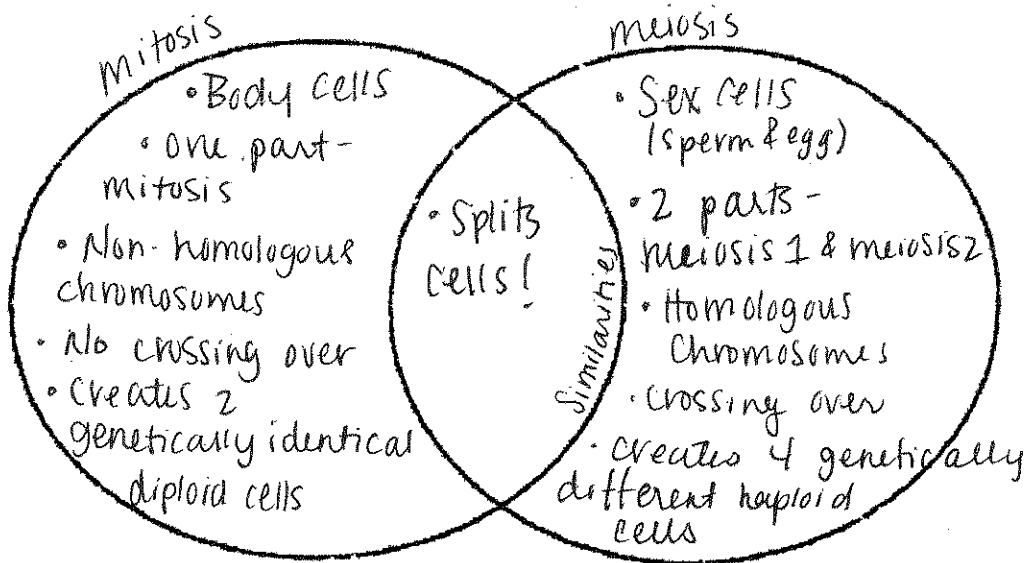

8. Draw the four stages of mitosis and briefly explain each stage.

Mitosis				
Stages	Prophase	Metaphase	Anaphase	Telophase
Drawing				
Description	<ul style="list-style-type: none"> <li>* Nuclear membrane disappears</li> <li>* Chromosomes that have already doubled become visible</li> <li>* Centrioles &amp; spindle fibers form</li> </ul>	<ul style="list-style-type: none"> <li>* Chromosomes line up down the middle on the spindle fibers</li> </ul>	<ul style="list-style-type: none"> <li>* Spindle fibers shorten &amp; pull apart chromosomes into chromatids</li> </ul>	<ul style="list-style-type: none"> <li>* Nuclear membrane reforms around chromatids</li> <li>* Cell starts to split</li> </ul>

cells identical  
 \* Cells are diploid  
 \* 2 chromatids  
 \* X and one

9. Draw the eight stages of meiosis and briefly explain each stage

Meiosis								
Stages	Prophase 1	Metaphase 1	Anaphase 1	Telophase 1	Prophase 2	Metaphase 2	Anaphase 2	Telophase 2
Drawing								
Description	<ul style="list-style-type: none"> <li>* Homologous chromosomes become visible</li> <li>* Nuclear membrane disappears</li> <li>* Crossing over occurs</li> </ul>	<ul style="list-style-type: none"> <li>* Homologous chromosomes are pulled apart</li> </ul>	<ul style="list-style-type: none"> <li>* Homologous chromosomes line up down the center of cell</li> </ul>	<ul style="list-style-type: none"> <li>* Nuclear membrane reforms for a small bit</li> <li>* Cell splits</li> </ul>	<ul style="list-style-type: none"> <li>* Non-homologous chromosomes become visible</li> <li>* Nuclear membrane disappears</li> </ul>	<ul style="list-style-type: none"> <li>* Non-homologous chromosomes line up in center of cell.</li> </ul>	<ul style="list-style-type: none"> <li>* Non-homologous chromosomes are pulled apart into sister chromatids</li> </ul>	<ul style="list-style-type: none"> <li>* Cells split into 2-4 cells made genetically different</li> <li>* Amount of DNA</li> </ul>



**Unit Five: Genetics**

- On a separate sheet of paper, write the definitions for the following terms.
  - Allele
  - Homozygous
  - Heterozygous
  - Genotype
  - Phenotype
  - Complete Dominance
  - Incomplete Dominance
  - Co-Dominance
  - Genetics
  - Heredity
  - Recessive
  - Mutation
  - Autosomal
  - Sex-linked

- Identify the pedigree as autosomal or sex-linked and dominant or recessive. Then give the most probable genotype of each individual.

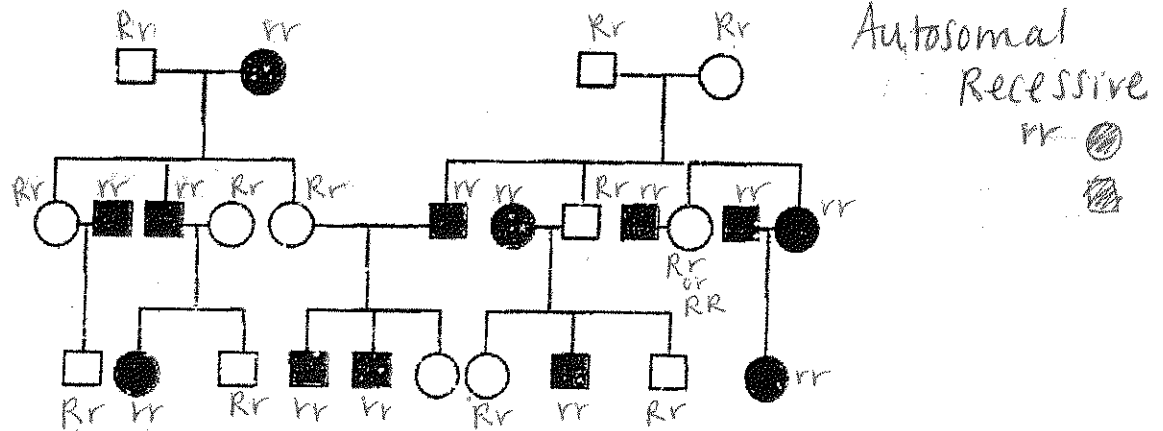

- Who is known as the "father" of genetics? What did he study? Why did he study this?

Gregor Mendel - studied pea plants because they have 9

- Who is more commonly affected by sex-linked traits and why are they more commonly affected? *distinct traits.*
- Perform the following crosses using Punnett squares and give the requested ratio. G is dominant for green skin; g is recessive for blue skin. B is dominant for brown eyes; b is recessive for blue eyes.

a.  $Gg \times Gg$  (Genotypic Ratio)

	G	g	
G	GG	Gg	1GG: 2Gg: 1gg
g	Gg	gg	

b.  $Bb \times Bb$  (Phenotypic Ratio)

	B	b	
B	BB	Bb	3 brown eyes
b	Bb	bb	

1 blue eyes

- $GgBb \times GgBb$  (Genotypic and Phenotypic Ratio)

	GB	Gb	gB	gb	
GB	GGBB *	GGBb *	GgBB *	GgBb *	9 green skin / Brown eyes 3 green skin / Blue eyes 3 blue skin / Brown eyes 1 blue skin / Blue eyes.
Gb	GGBb *	GGbb Δ	GgBb *	Ggbb Δ	
gB	GgBB *	GgBb *	ggBB ○	ggBb ○	
gb	GgBb *	Ggbb Δ	ggBb ○	ggbb □	

- 1 GG BB
- 2 GG Bb
- 2 Gg BB
- 4 Gg Bb
- 1 GG bb
- 2 Gg bb
- 1 gg BB
- 2 gg Bb
- 1 gg BB
- 2 gg Bb

**Unit Six: DNA**

1. On a separate sheet of paper, write definitions for the following terms
 

a. DNA Replication	f. Amino Acid Translation
b. Nucleotide	g. Codon
c. Nucleic Acid	h. Anticodon
d. Mutation	i. DNA Fingerprint
e. RNA Transcription	

2. Describe the structure of DNA. Include all of the various parts that make up DNA.  
 DNA is made up of nucleotides - which is composed of a sugar, phosphate and one of four nitrogen bases, A, T, C, G.
3. Explain how a DNA fingerprint can be used to solve crimes. DNA is double stranded & is unique to each person when DNA is left @ a crime scene - it can be analyzed & used to identify a suspect.  
 DNA has its own fingerprint that is a double helix - like a twisted ladder.
4. Compare and contrast DNA and RNA. Which one is the blueprint of life?  
 DNA is the blueprint of life. Both carry genetic information & have adenine, guanine, & cytosine. RNA contains Ribose, Uracil & is single stranded.
5. What are the base pairing rules for...? DNA is double stranded, contains thymine & deoxyribose.

- a. DNA?
 

A-T	G-C
-----	-----
- b. RNA?
 

A-U	T-A	G-C
U-A	C-G	

6. Answer the following questions based on the DNA sequence: **TACGCCTTG**
  - a. What will the complimentary DNA strand look like?

~~ATGCGGAAAC~~ **ATGCGGAAAC**

- b. Transcribe the DNA into a strand of mRNA

**UAC-GCC-UUG**

- c. Translate the mRNA into a protein chain (you need your codon chart for this)

**Tyr - Ala - Leu**

7. Describe the process of protein synthesis in detail.

① DNA Replication: DNA makes an exact copy of itself. This happens by unzipping & free floating nucleotides attach themselves. It takes place in the nucleus. ② RNA transcription - RNA nucleotides attach themselves to the bottom strand of DNA. A-U, T-A, G-C, C-G. ③ Amino Acid Translation

8. There are three main types of mutations. List and briefly describe them.

Substitution ← a. Point mutations - ~~one~~ a couple DNA bases are changed

addition/deletion ← b. Frameshift mutations - a couple DNA bases are added or deleted

Inversion ← c. Chromosomal mutations - many DNA bases are added, deleted, or changed.

9. Does every mutation cause damage to an organism? Explain your answer.

No not all mutations cause damage - some mutations can be good & add a genetic variation with in the population that has an advantage.

RNA is broken into codons (sets of 3 bases) and matched w/ an amino acid. The amino acids bond and fold into a protein. Shape of protein determines the function.

**Unit Seven: Evolution**

1. On a separate sheet of paper, write definitions for the following terms
  - a. Evolution
  - b. Natural Selection
  - c. Adaptation
  - d. Fossil
  - e. Homologous Structure
  - f. Vestigial Structure
  - g. Analogous Structure
  - h. Species
  - i. Competition

2. Where did Darwin do most of his research?

*Galapagos Islands*

3. Explain natural selection.

*Survival of the fittest or strongest species, the ones w/ the best natural defenses / advantageous variations will survive.*

4. List and describe some variables that cause evolution.

*① Natural Selection - see above ② mutations - mutation in parents DNA. ③ Genetic Drift - when a population changes by chance*

5. If a population is not evolving, this means that the population is in what?

*The population is in equilibrium!*

*④ Gene flow - movement of organisms to a new area*

*⑤ Non-Random mating - organisms choose their mates.*

6. Of the items listed below, circle any that could contribute to natural selection.

- a. Phenotypic Variation*
- b. Genetic Variation*
- c. Renewable Water Supply*
- d. Environmental Change*
- e. Limited Living Space*
- f. Climate Change*
- g. Unlimited Resources*
- h. Mutation*
- i. Food Source*

7. There are three types of natural selection that can occur. Identify each of the graphs below as either Stabilizing Selection, Disruptive Selection, or Directional Selection. Be sure to provide an explanation of each type of natural selection.

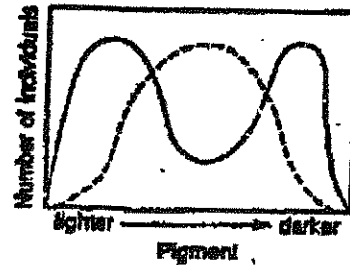
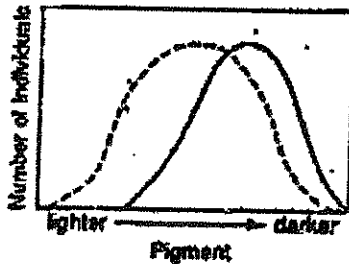
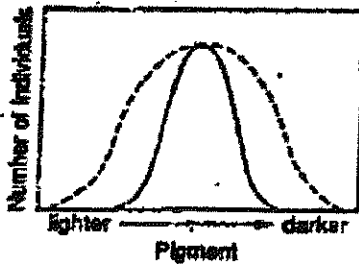

Type of Selection	<i>Stabilizing</i>	<i>Directional</i>	<i>Disruptive</i>
Description of Selection	<i>Removes extreme phenotypes</i>	<i>Increases the occurrence of one extreme phenotype</i>	<i>Removes average traits, favors both extremes.</i>

8. List and explain the 4 requirements for natural selection

- a. Variation - Individuals in a population that has differences
- b. Heritability - Variations inherited by from parents
- c. Overproduction - populations produce more offspring than can survive.
- d. Reproductive Advantage - Some variations allow organisms to have more offspring than other organisms

9. List and explain the six pieces of extra evidence for evolution

- a. Mimicry - one organism over time looks like another
- b. Anatomical characteristics - Structural specializations that help the organism adapt.
- c. Camouflage - Organisms develop adaptations that allow them to blend in with their environment.
- d. Embryology - Studying the growth & development of organisms
- e. Change in DNA - mutations
- f. Fossils - horses foot!

10. Explain speciation as it relates to Darwin's finches. What key adaptations in the finches is affected by the type of food available? Speciation is caused by adaptive radiation where one species migrates to a new area & adapt to that area - forming a new species, this happened to the finches on the

11. Compare and contrast homologous structures and analogous structures. Give an example of each.

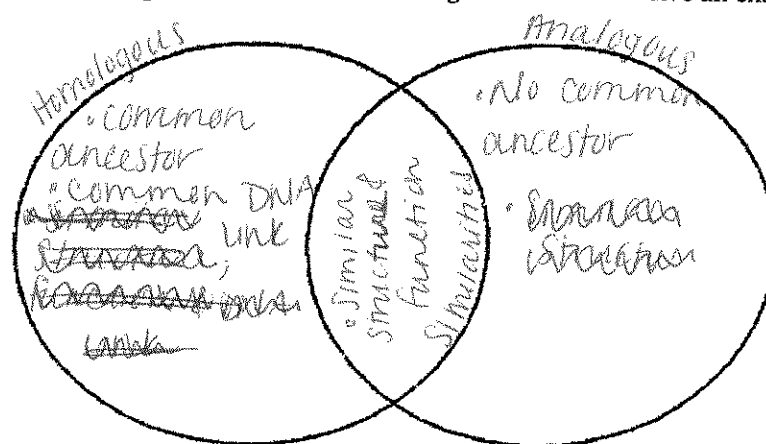

galapagos Islands. Only specific food was available to eat & some beaks could not survive on certain food & some could - Creating ~~two~~ different species.

12. Name two vestigial structures in humans

- a. Appendix
- b. Wisdom teeth

## Unit Eight: Populations & Ecology

1. On a separate sheet of paper, write definitions for the following terms

- |                       |                      |                         |
|-----------------------|----------------------|-------------------------|
| a. Producer           | e. Habitat           | l. Biome                |
| b. Primary Consumer   | f. Carrying capacity | m. Abiotic Factors      |
| c. Secondary Consumer | g. Ecology           | n. Community            |
| d. Tertiary Consumer  | h. Ecosystem         | o. Secondary Succession |
|                       | i. Biotic Factors    | p. Primary Succession   |
|                       | j. Biodiversity      |                         |
|                       | k. Population        |                         |

2. There are five types of symbiotic relationships. Name, define, and provide an example of each below.

a. mutualism - both species benefit - Bee & flower

b. Commensalism - one species benefits, the other species is neither harmed nor benefitted. Remora fish & Sharks

c. Parasitism - one species benefits, the other species is harmed. Mosquitoes & animals

d. predator/prey - one species benefits by eating the other. Lion & zebra

e. Invasive species - foreign species that are introduced to a new area. Not native. No two species can occupy the same niche - Asian Carp

Community Relationships

3. Draw a food web in the space below based on the following food chains:

- Plants → Mouse → Hawk
- Plants → Rabbits → Wolf
- Plants → Rabbits → Snake → Hawk
- Plants → Mouse → Snake
- Plants → Deer → Wolf
- Plants → Hawk → Wolf

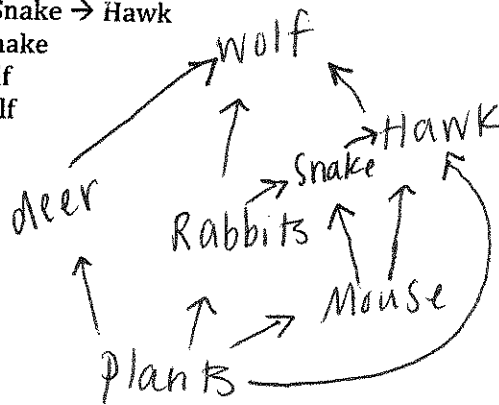

4. Provide examples from the food web above for each of the following

- |             |                     |                       |                      |
|-------------|---------------------|-----------------------|----------------------|
| a. Producer | b. Primary Consumer | c. Secondary Consumer | d. Tertiary Consumer |
| plants      | Rabbit              | Snake                 | Hawk                 |

5. Most ecosystems only contain four trophic levels. Based on your food web from #2, explain which trophic level(s) the wolf feeds at and why. The wolf feeds at the secondary consumer level.

6. Explain how much energy moves up through the trophic levels and why there is not a 4<sup>th</sup> level consumer.

only 10% of energy is passed through each trophic level. 90% is lost as heat & there is not enough energy to sustain a 4<sup>th</sup> level.

7. Explain how primary succession differs from secondary succession. How are they similar? Why is succession important?

Primary Succession starts out when there is no soil & eventually turns into an entire ecosystem. Secondary Succession happens when there is a natural disaster to an already established area. They both create more bio-diversity.

8. Use the graph to answer the questions

a. Which section shows an increase in birth rate?

B

b. Which section show an increase in death rate?

D

c. Why does the graph level off in second C?

Carrying capacity

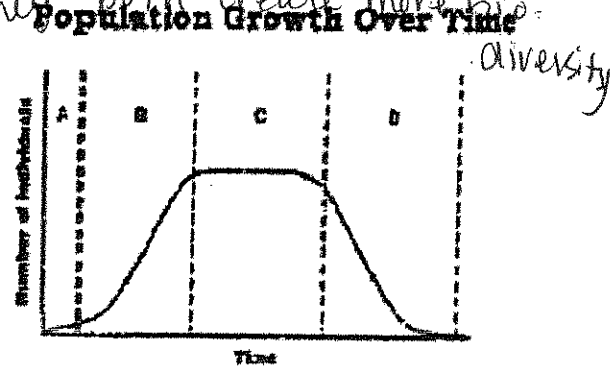

9. What factors cause population growth to increase?

Food, Resources

10. What factors cause population growth to decrease?

Lack of resources

11. Explain the following cycles (you may sketch a diagram if that's easier)

a. Water Cycle

Precipitation, Runoff, ground water, oceans, lakes & streams, evaporation & transpiration, condensation.

b. Carbon Cycle

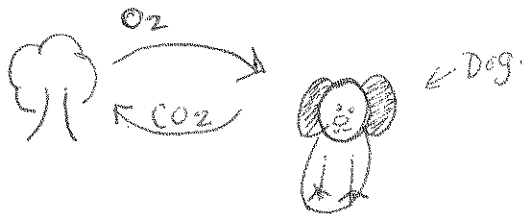

c. Nitrogen Cycle

①  $N_2$  mixes w/ rain water

② Nitrogen fixation -  $N_2 \rightarrow NH_3$

↳ Animals & decaying leaves release  $NH_3$

③  $NH_3 \rightarrow NO_2 \rightarrow NO_3$  (Nitrate)

④ plants take in  $NO_3$

⑤ Animals eat plants

⑥ Some bacteria take in  $NO_3$  & release  $N_2$  into Atmosphere

⑦ Volcanic Activity releases  $N_2$  into Atmosphere.